



The Next Revolution in Frozen Drinks

The only Frozen Drink
Machine with a Twist!



Model DH10

This innovative freezer allows you to serve two separate flavors or swirl them together for a signature drink. Electro Freeze is the first and only manufacturer to offer this unique design.*

Dispensing Head

Clear and durable acrylic dispensing head creates visual appeal. Merchandising your signature drinks to your customers.

Construction

Sturdy angle iron frame, stainless steel mix hoppers, beaters and freezing cylinders.

Mix Level Indicator

Low mix lights automatically tell operator when mix is needed.

Unique Beater Design

Allows the operator to serve a consistent stackable drink.

Electronic Torque Monitor

Continuously monitors product thickness to produce the most consistent frozen product available.

Refrigeration

One H.P. low temp compressor for fast and efficient freeze-down and quick recovery.

Freezing Cylinders

Durable polished stainless steel, two 8 quart, foam insulated for maximum efficiency.

Mix Hoppers

Refrigerated, two 8 quart stainless steel hoppers for optimum performance.

Optional

Auto fill system for high volume applications.



* Patent Pending

Sweet Choice!

ELECTRO FREEZE

ELECTRO FREEZE®

PLUMBING AND ELECTRICAL CONNECTIONS

BATCH

FROZEN COCKTAIL

SLUSH

SHAKE

YOGURT

SOFT SERVE

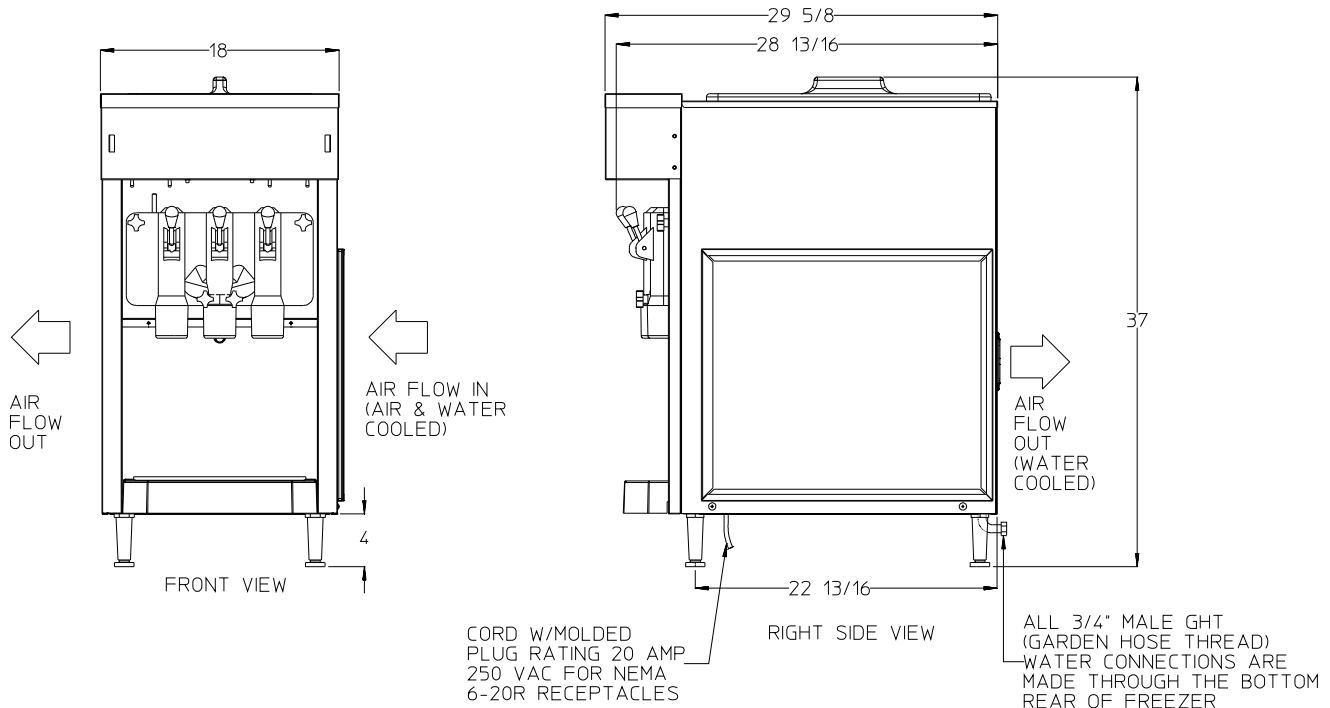

SPECIFICATIONS

All specifications subject to change without notice. Check name plate for exact electrical data.

MODEL NO.	MOTOR HP		DIMENSIONS			WEIGHT	TOTAL AMPS	
	Beater	Compressor	D.	W.	H.		Air Cooled	Water Cooled
DH10	TWO .25 HP	1 HP 8000 BTU	29-5/8" 75.3 CM	18" 45.7 CM	37" 94 CM	300 LB 136 KG	12	11

Air or water cooled. Self contained only. Allow 3" clearance on sides and rear of unit for air circulation.

Wiring - 208/230 volt, A.C., 60 Cy., 1 Phase; 20 AMP service.

Connects to a standard NEMA 6-20R receptacle.

Electrical characteristics other than above available on request from sales office.

Hopper Capacity: (2) 8 quarts each (7.6L)

Freezing Cylinder Capacity: (2) 8 quarts each (7.6L)

Refrigerant; 404a

Authorized Distributor

division of H.C. DUKE & SON, INC.

2116-8th AVENUE, EAST MOLINE, ILLINOIS 61244

Phone (309) 755-4553 • (800) 755-4545

FAX (309) 755-9858

E-mail: sales@electrofreeze.com • www. electrofreeze.com

184272 Printed in U.S.A. 8/09

Certified and/or listed by:



*Listed by Underwriters Laboratories under Canadian National Standard C22.2 No. 120-M91