

Compact Series

Twist Gravity Soft Serve Machine

Model FM8

Twist flavor soft serve machine. The "Compact Series" is developed to save space, yet big enough to turn up to 80% profits on every serving. Top off your business with Electro Freeze "Compact Series" machines.

Special Features

Construction

Sturdy angle iron frame, stainless steel mix hoppers, beaters and freezing cylinders.

Mix Level Indicator

Low mix lights automatically tell operator when mix is needed.

Axial Flight Beater

Precision crafted and machined to exacting standards resulting in a superior quality product, with fewer parts.

Dispensing Head

Finest insulating material available...no frost, no drip. Easy pull-down handle with self closing spigot.

Mix Feed

Specially designed to maintain optimum overrun.

Refrigeration

Two 3/4 H.P. low temp compressors permit fast freeze-down and quick recovery.

Freezing Cylinder

Two 2.5 quart, polished stainless steel, foam insulated for maximum efficiency.

Mix Hopper

Two 10 quart, refrigerated stainless steel, foam insulated.

Night Switch

Provides controlled refrigeration of product during night or any non-business period...reduces product deterioration.



Model FM8

ELECTRO FREEZE®

Plumbing & Electrical Connections

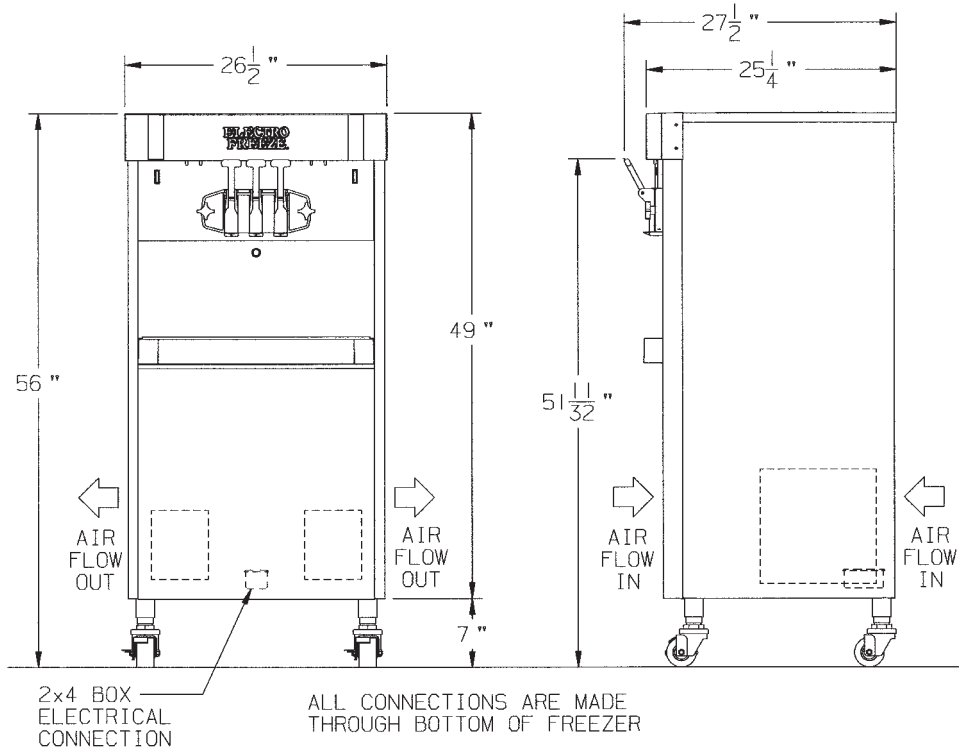

Model FM8

SPECIFICATIONS

All specifications subject to change without notice.

MODEL NO.	MOTOR H.P.		DIMENSIONS			NET WT.	TOTAL AMPS
	Beater	Compressor	D.	W.	H.		
FM8	Two .75 HP	Two .75 HP 4300 BTU	25" 64.1 CM	26.5" 67.3 CM	56" 142.2 CM	470 LB. 213 KG.	16

Air cooled. Self contained only. Allow 3" clearance on sides and rear of unit for air circulation.

WIRING - 208/230 volts, A.C., 60 cycle, 1 Phase; 20 AMP service.

Connects to a standard NEMA 6-20R receptacle.

Electrical characteristics other than above available on request from sales office.

HOPPER CAPACITY: Two - 10 quarts each (9.4L)

FREEZING CYLINDER CAPACITY: Two - 2.5 quarts each (2.4L)

REFRIGERANT: R404a

Authorized Distributor

division of H.C. DUKE & SON, INC.

2116 - 8th Avenue • East Moline, Illinois 61244

Phone (309) 755-4553 • (800)755-4545

Fax (309) 755-9858

E-mail: sales@electrofreeze.com • www.electrofreeze.com

Certified and/or listed by:



*UL listed and listed by Underwriters Laboratories under Canadian National Standard C22.2 No. 120-M91

**Select Voltages @ 50 HZ